

# FGC-series

cyclic use range

## Valve regulated lead-acid batteries



To better respond to the requests of specific market sectors and increasing market demands.

Applications: Golf Carts and Buggies - Electric Powered Mobility Vehicles - Electric Lawn Mowers - Photovoltaic Systems - Electric Power Tools - Toys

### Technical information

Battery Model		FGC21803	FGC22703	FGC24204
Nominal Voltage		12V	12V	12V
Nominal Capacity	at 20 hours rate	18Ah	27Ah	42Ah
	at 10 hours rate	15,3Ah	23Ah	38Ah
	at 5 hours rate	14,4Ah	20,5Ah	35Ah
	at 1 hour rate	10,8Ah	14,9Ah	22,8Ah
Dimensions (mm)	Length	181	166	196
	Width	76	175	163
	Height	167	125	174
Approximate weight		6,3 kg	9,4 kg	14 kg
Terminals		Bolt M5	Bolt M5	Bolt M6
Internal Resistance		15 mΩ	12 mΩ	6 mΩ
Recommended charging voltage		14,4-14,8V	14,4-14,8V	14,4-14,8V
Recommended maximum charging current		4,5 A	6 A	10 A
Shelf life. % of nominal capacity remaining	after 1 month	97%	97%	97%
	after 3 months	91%	91%	91%
	after 6 months	83%	83%	83%
Storage temperature range		-20 to 40°C	-20 to 40°C	-20 to 40°C
Charging temperature range		0 to 40°C	0 to 40°C	0 to 40°C
Discharging temperature range		-20 to 50°C	-20 to 50°C	-20 to 50°C
Case material for all the models:		Acrylonitrile-Butadiene-Styrene.		
		Standard version: According to UL-94 HB		

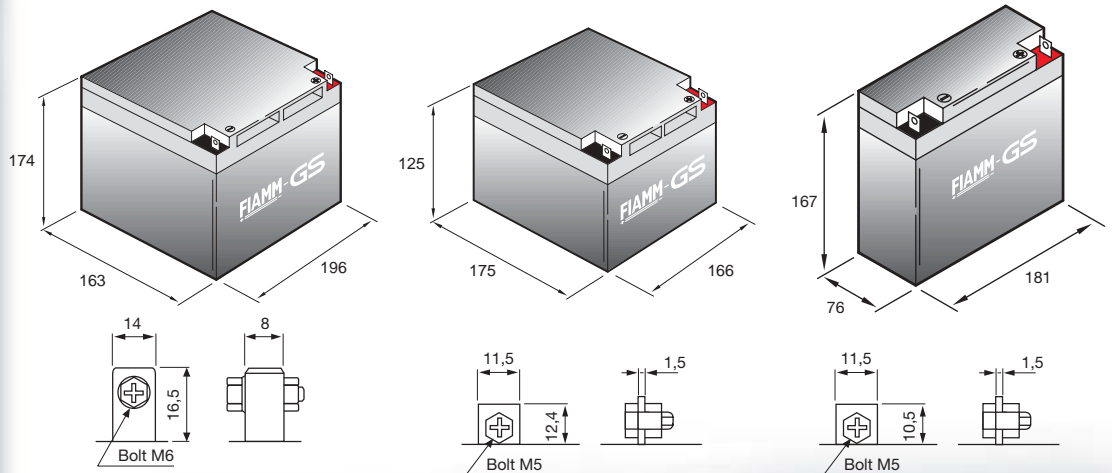

# FIAMM-GS



## Valve regulated lead-acid batteries

### Lifetime in cyclic use

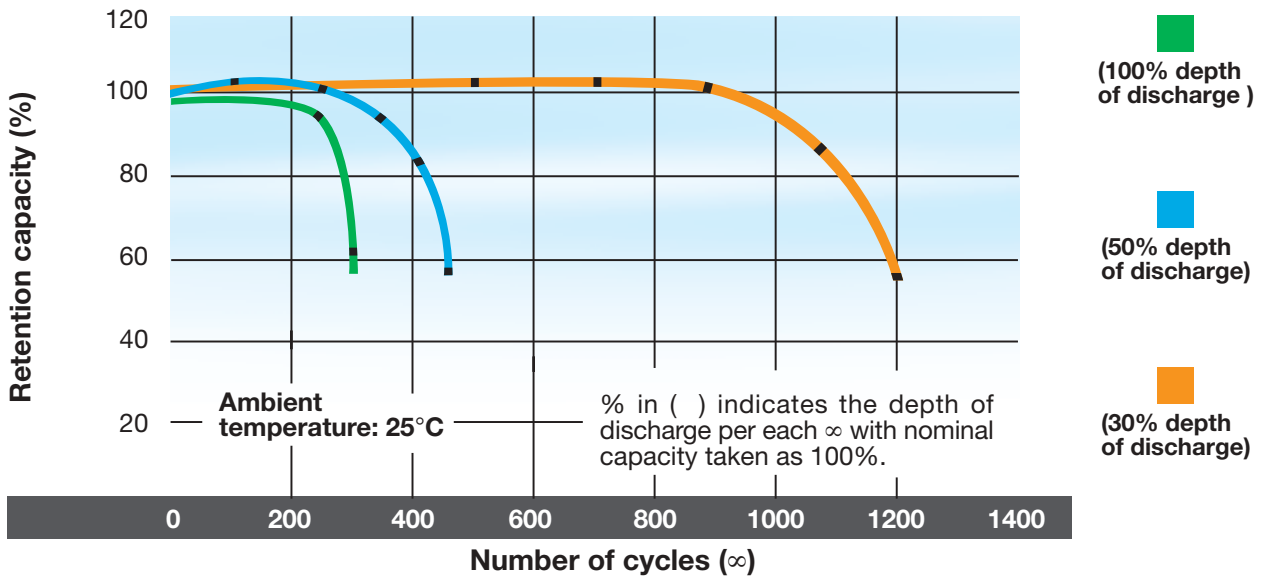

A battery is an investment and the choice of the most suitable battery is the result of the correct evaluation of the technical and economical factors involved. The FIAMM-GS cyclic range of batteries have, as the name implies, been designed to maximise the number of cycles it can perform. In order for these batteries to achieve maximum performance and maximum number of cycles, they need to be maintained well and it is for this reason that FIAMM-GS has now developed its own range of electronic chargers.

### Charging diagram

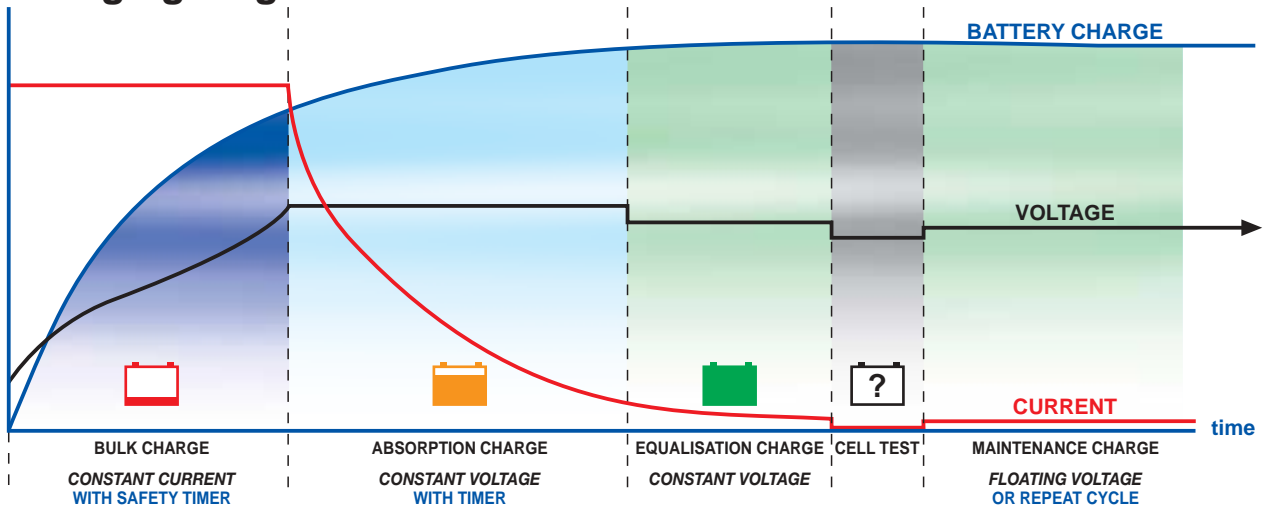

The recommended charging current (A) is 20% of the battery capacity (Ah). However a charging current of anywhere between 10% and 30% can be used with the effect being on the recharge time.

As an indicator; approx recharge time = battery capacity x 2 / charging current

# FIAMM-GS

Viale Europa, 63  
 36075 Montecchio Maggiore - VICENZA - ITALY  
 Tel. +39 0444 709350 (r.a.) - Fax +39 0444 709360  
<http://www.fiamm-gs.com>